

DATA SHEET

PRESSURE SENSITIVE REGULATING UNLOADER



The Pumps with Nine Lives

Brass Models: 7600S



FEATURES

- Maintains full system pressure while running in by-pass without full load on pump.
- Offers pump protection against pressure fluctuations and system changes.
- Minimum pressure fluctuations with alternating use of multiple guns.
- Adjusting cap permits easy adjustments of pressure.

SPECIFICATIONS

	U.S.	Metric
Flow Range	2.0 - 5.0 gpm	7.6 - 19.0 lpm
Pressure Range	700 - 3500 psi	48 - 241 bar
Maximum Temperature	180° F	82° C
Inlet Port	3/8" NPT(M)	3/8" NPT(M)
By-Pass Port	3/8" NPT(F)	3/8" NPT(F)
Outlet Port	3/8" NPT(M)	3/8" NPT(M)
Weight	21.6 oz.	0.61 kg
Dimensions	3.25 x 1.0 x 5.0"	82 x 25 x 127 mm

For Relief Valve version add .100 to unloader model number.

SELECTION

These are pressure sensitive regulating unloaders, designed for systems with single or multiple pumps, solenoid (gate) valves, nozzles, standard or “weep” guns.

Note: For multiple pump systems, it is best to use a pressure regulator not a pressure sensitive regulating unloader.

These pressure sensitive regulating unloaders should meet both the desired system flow (combined nozzle flow rate requirement) and the desired system pressure.

Notice: Operation below the minimum flow of the unloader causes the unloader to cycle. Operation above the maximum flow of the unloader causes premature unloader wear, cycling and prevents attaining desired system pressure.

INSTALLATION

These unloaders operate properly when mounted in any direction, however, it is preferred to keep the plumbing to a minimum and the hex adjusting cap easily accessible. The best mounting location is directly onto the pump discharge manifold head.

The inlet connection is a 3/8” NPT(M) sized port located on the back side of the unloader. An arrow is cast into the body indicating the direction of flow through the valve. Liquid from the discharge of the pump goes through this connection.

The discharge connection is a 3/8” NPT(M) sized port located on the front side (hex end). An arrow and the word OUT is cast into the body indicating the direction of flow. Plumbing for spray guns, solenoid (gate) valves or nozzles is connected here.

The by-pass connection is a 3/8” NPT(F) sized port located on the bottom. By-Pass liquid is directed out of this port and can be routed to a reservoir (preferred method), or to a drain or to the pump inlet.

OPERATION

These pressure sensitive regulating unloaders hold established system pressure in the discharge line when the trigger gun is closed or solenoid (gate) valve is closed or the nozzle is clogged, thus by-passing all unrequired flow. Squeezing the trigger gun or opening the solenoid (gate) valve will close off the by-pass and return to established system pressure without delay.

PRESSURE ADJUSTMENT

1. Setting and adjusting the unloader pressure must be done with the system “on”.
2. Start the system with unloader backed off to the lowest pressure setting (counterclockwise direction).
3. Squeeze the trigger and read the pressure on the gauge at the pump.
Note: Do not read the pressure at the gun or nozzle.
4. If more pressure is desired, release the trigger, turn hex adjusting cap one quarter turn in clockwise direction.
5. Squeeze the trigger and read the pressure.
6. Repeat this process until desired system pressure is attained.
7. Once the desired system pressure is reached, stop turning the hex adjusting cap.

Note: Pressure is not set at the factory.

Notice: A minimum by-pass flow of 5% of the unloader rated flow capacity is required for proper unloader performance. If the entire out is directed through the nozzle (zero by-pass) the “cushioning” feature of the by-pass liquid is eliminated and the unloader can malfunction or wear prematurely.

8. If desired system pressure cannot be reached, review TROUBLESHOOTING chart.
9. When servicing existing systems, follow adjustment procedures as stated above for new unloaders.

Note: Do not adjust unloader pressure setting to compensate for a worn nozzle. Check the nozzle as part of the regular maintenance and replace if worn.

Note: A secondary pressure relief device (i.e. pop-off valve) should be used along with this pressure sensitive regulating unloader. Final adjustment for the relief valve should relieve at 200 psi above the system operating pressure.

Note: By removing the check valve and spring, these unloaders can function as relief valves.

TYPICAL UNLOADER INSTALLATION

1. Pressure Gauge
2. Relief Valve
Shown as a secondary relief valve
3. Pulsation Dampener
4. Pressure Sensitive Regulating Unloader
5. Triplex Plunger Pump

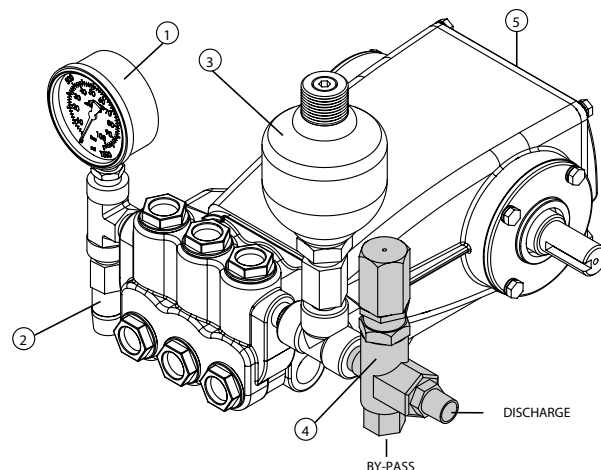

SERVICING

Disassembly

1. Disconnect by-pass, discharge and inlet plumbing from unloader.
2. Remove unloader from pump.
3. Secure body of unloader in a vise with hex adjusting cap facing up.
4. Remove discharge fitting and o-ring, spring, check valve and o-ring, collar, check valve seat and o-ring.

Note: Seat for check valve will remain in the unloader. Exercise caution in removing to avoid damage to unloader walls and seat.

5. Examine check valve, check valve seat, collar and discharge fitting for wear, spring for wear or fatigue and o-rings for cuts or wear and replace as needed.

Note: While the discharge fitting is removed, inspect sealing area where the check valve makes contact within the internal body of the unloader for grooves, pitting and wear. If damage is found, stop the repair and replace with complete new unloader. If not, proceed with disassembly.

6. If supplied with a lock nut, the lock nut does not need to be removed. Turn lock nut down towards unloader body.
7. Remove hex adjusting cap by turning in a counterclockwise direction.
8. Remove spring and spring retainer.
9. Examine spring and spring retainer for scale build up, fatigue or wear and replace as needed.
10. Remove by-pass fitting with o-ring from bottom port.
11. Remove seat with o-ring from the male threaded side of by-pass fitting.
12. Examine seat for scale build up, scoring and wear and replace as needed. Examine o-ring for cuts or wear and replace as needed.
13. Removal of piston stem and valve/ball assembly requires the use of a small hex socket and screwdriver. Insert screwdriver from the top and place in slotted head of piston stem. Insert small hex socket into bottom port and secure valve/ball assembly. Unthread by turning in a counterclockwise direction.
14. Examine piston stem and valve/ball assembly for scale build up, scoring, pitting and wear and replace as needed. Examine o-rings and backup ring for cuts or wear and replace as needed.
15. Remove piston retainer with o-rings and backup rings by turning in a counterclockwise direction.
16. Examine piston retainer for wear. Examine o-rings and back-up-ring for cuts or wear and replace as needed.

Reassembly

1. Lubricate and install small body back-up-ring and then body o-ring into unloader body.
2. Lubricate and install o-ring over threads of piston retainer.
3. Carefully hand thread piston retainer with small diameter hole facing down into unloader body and tighten with a wrench.
4. Lubricate and install o-ring over piston stem head and then backup-ring into groove of piston stem.
5. Apply Loctite® 242® to the last few threads of the piston stem.
6. Insert piston stem from the top through the piston retainer until seated.
7. Using the same tools in removing the piston stem and valve/ball assembly, place valve/ball assembly into hex socket tool with ball surface facing down into socket. Place screwdriver tip into piston stem slotted head. Thread piston stem into valve/ball assembly.
8. Place by-pass fitting on flat surface with male threads facing up.
9. Lubricate and install o-ring onto seat. Press seat into by-pass fitting. Hand thread by-pass fitting into lower port of unloader body and tighten with wrench.
10. Lubricate and install o-ring on discharge fitting.
11. Lubricate and install o-ring onto check valve seat. Insert check valve seat with o-ring into unloader body. Install collar with notches facing in towards check valve seat. Insert spring into discharge fitting, then insert check valve with small step end into spring. Hand thread into unloader body and tighten with wrench.
12. Place spring retainer on top of piston stem.
13. Place spring on to spring retainer.
14. Thread hex adjusting cap onto piston retainer.
15. Remove unloader from vise.
16. Re-install unloader onto pump.
17. Reconnect by-pass, discharge and inlet plumbing to unloader.
18. Proceed to PRESSURE ADJUSTMENT.

Loctite® and 242® are registered trademarks of the Henkel Corporation.

TROUBLESHOOTING

Unloader cycles	<ul style="list-style-type: none"> • Worn O-ring or check valve • Fitting leaking downstream • Air in system, poor connection. 	<ul style="list-style-type: none"> • O-ring in gun worn • Insufficient flow through unloader.
Liquid leaking from bottom	<ul style="list-style-type: none"> • O-ring for seat or inlet fitting cut or worn 	<ul style="list-style-type: none"> • O-ring for seat cut or worn.
Liquid leaking from middle	<ul style="list-style-type: none"> • O-ring for piston cut or worn 	<ul style="list-style-type: none"> • O-rings for piston stem cut or worn
Unloader will not come up to pressure	<ul style="list-style-type: none"> • Not properly sized for system pressure • Foreign material in unloader • Piston stem o-rings worn 	<ul style="list-style-type: none"> • Nozzle worn or too large • Insufficient flow to pump
Extreme pressure spikes	<ul style="list-style-type: none"> • Adjusting handle turned completely into unloader • Restricted by-pass or no by-pass 	<ul style="list-style-type: none"> • System flow exceeds unloader rating
Filtration	<ul style="list-style-type: none"> • Clean filter on regular schedule to avoid cavitation. 	

PRESSURE READING

Approximate Pressure Reading at Gauge	Gauge Between Pump/ Unloader	Gauge Between Unloader/ Gun-Nozzle-Valve
System in Operation (Gun Open)	System Pressure	System Pressure
System in By-Pass (all guns, valves closed)	Low Pressure 0 - 150 psi	System Pressure +200 psi

EXPLODED VIEW

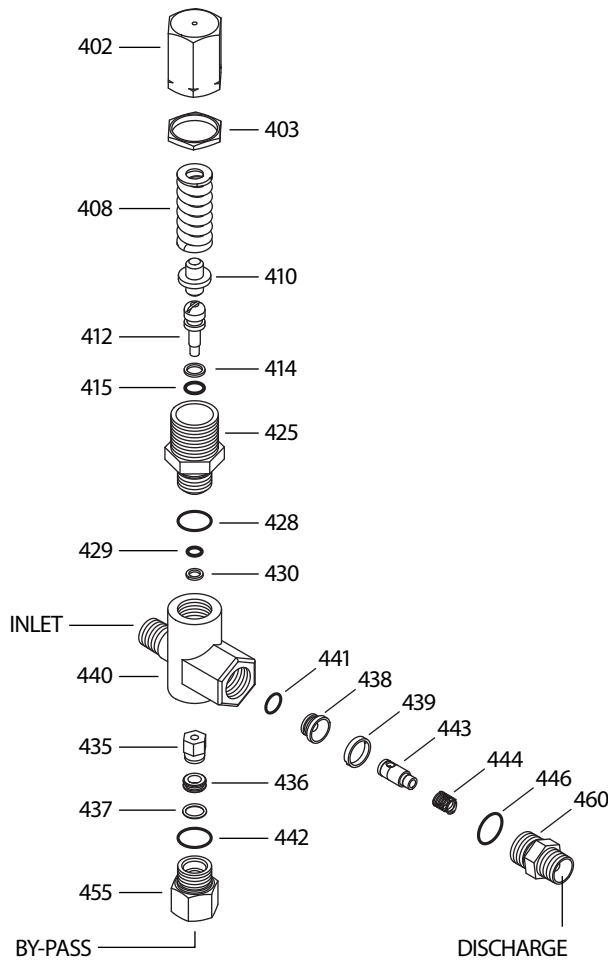

PARTS LIST

ITEM	P/N	MATL	DESCRIPTION	QTY.
402	45197	BB	Cap, Hex Adjusting	1
403	45201	BB	Nut, Lock (M25x1)	1
408	45198	ZP	Spring, Pressure	1
410	45199	STZP	Retainer, Spring	1
412	45694	S	Stem, Piston (M5)	1
414	20184	PTFE	Back-up-Ring, Piston Stem	1
415	14190	NBR	O-Ring, Piston Stem - 70D	1
425	45200	BB	Retainer, Piston	1
428	26133	NBR	O-Ring, Piston Guide - 80D	1
429	14759	NBR	O-Ring, Body	1
430	107675	PTFE	Back-up-Ring, Body	1
435	45716	S	Valve and Ball Assembly (M5)	1
436	107680	S	Seat	1
437	26127	NBR	O-Ring, Seat	1
438	45206	S	Seat, Check Valve	1
439	45205	BB	Collar	1
440	—	BB	Body	1
441	13963	NBR	O-Ring, Check Valve seat - 70D	1
442	26133	NBR	O-Ring, Adapter - 80D	1
443	35203	BB	Valve, Check w/O-Ring	1
444	45924	S	Spring, Check Valve	1
446	26133	NBR	O-Ring, Discharge Fitting - 80D	1
455	45695	BB	Fitting, By-Pass [3/8" NPT(F)]	1
460	107681	BB	Fitting, Discharge [3/8" NPT(M)]	1
468	32098	NBR	Kit, O-Ring (Incls: 414,415,428,429,430,437,441,442,446)	1

Italics are optional items.

MATERIAL CODES (Not Part of Part Number):

BB=Brass NBR=Medium Nitrile (Buna-N) PTFE=Pure Polytetrafluoroethylene
S=304SS STZP=Steel/Zinc Plated ZP=Zinc Plated

⚠ CAUTIONS AND WARNINGS

All High Pressure Systems require a primary pressure regulating device (i.e. regulator, unloader) and a secondary pressure relief device (i.e. pop-off valve, relief valve). Failure to install such relief devices could result in personal injury or damage to pump or property. Cat Pumps does not assume any liability or responsibility for the operation of a customer's high pressure system.

Read all CAUTIONS and WARNINGS before commencing service or operation of any high pressure system. The CAUTIONS and WARNINGS are included in each service manual and with each Accessory Data sheet. CAUTIONS and WARNINGS can also be viewed online at www.catpumps.com/cautions-warnings or can be requested directly from Cat Pumps.

WARRANTY

View the Limited Warranty on-line at www.catpumps.com/warranty.



CAT PUMPS

1681 - 94TH LANE N.E. MINNEAPOLIS, MN 55449-4324
PHONE (763) 780-5440 — FAX (763) 780-2958
e-mail: techsupport@catpumps.com
www.catpumps.com